

Diverter Screen Changer TASK

for continuous filtration with start-up diverter

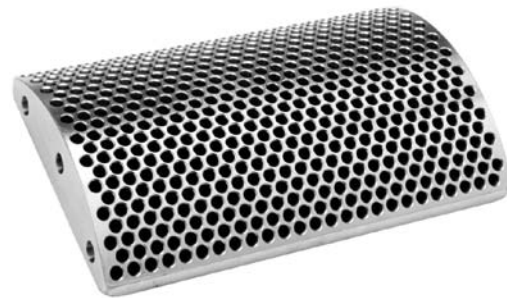

- Two screen cavities
- Continuous operation
- Rectangular breaker plate



Continuous screen changers from Trendelkamp are built to meet the highest quality standards in polymer melt filtration. TASK screen changers are based on the proven dual bolt design and are highly reliable.

Unique to all Trendelkamp screen changers are the curved and rectangular breaker plates. Utilizing this rectangular design offers a large screen area for the required bolt size, enabling smaller overall machine size to operate greater throughputs. Furthermore, our thin, curved breaker plate design optimizes strength while maintaining more uniform bore length throughout the plate.

The integrated diverter feature makes the start-up process easier and more efficient.

Benefits:

- Reliable continuous operation
- Fewer screen changes and lower screen cost
- Reduced shear stress on product
- Reduced pressure drop across screen changer
- Safe, easy operations and reduced maintenance
- Reduced extrusion line length
- No additional diverter valve and hydraulic unit required

Options:

- Oil, steam or electrical heating
- High-temperature design, up to 450°C
- Special coating for abrasive/corrosive applications
- Stainless steel design
- Hazardous area design

Diverter Screen Changer TASK



Functional Principle:

A rheological optimized flow channel divides the incoming polymer melt into two screen cavities equally. Inside the screen cavity a breaker plate is equipped with a filtration screen pack suitable for the required filtration fineness. Downstream of the screens the filtered melt streams converge and flow out of the screen changer housing as a single stream.

When a screen change is required, one bolt is moved hydraulically out of the housing so the screen pack can be changed. The other bolt remains in operating position and continues the melt flow. Before the bolt resumes operation, it moves to a venting position to prevent air from entering the process. These steps are then repeated for the other bolt.

The integrated divert feature allows the start-up melt stream to be diverted and purged from downstream processing.

Control Options:

- PLC control system (automatic venting)
- Control system preparation for external PLC
- Heating control system
- Pressure and temperature monitoring

Features:

- Hydraulically operated
- Operating limits: 400 bar/400°C
- Differential pressure: up to 100 bar
- Energy efficient due to insulated housing
- LED Heating status indicator (from TASK 6-2)
- LED Bolt maintenance indicator (from TASK 6-2)

Applications:

- Compounding
- Masterbatch

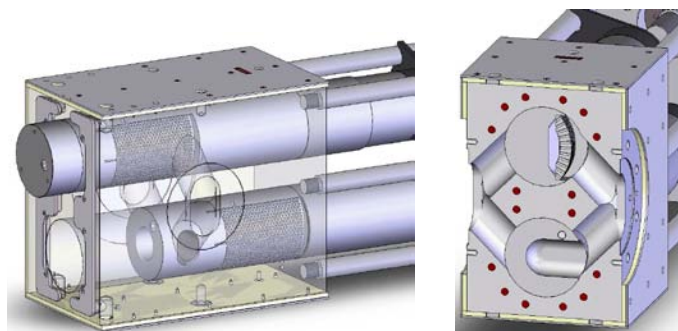

Start-up position

Diverter Screen Changer TASK >>> Data based on: Polyolefin's, Filter fineness 200 µm				
Model	Filter Area	Extruder Throughput	Heating Power	Hydraulic Power
TASK 3-2	2 x 48 cm ²	80 - 300 kg/h	2.7 kW	3.0 kW
TASK 4-2	2 x 87 cm ²	180 - 500 kg/h	5.4 kW	5.5 kW
TASK 5-2	2 x 161 cm ²	350 - 1,100 kg/h	8.4 kW	7.5 kW
TASK 6-2	2 x 270 cm ²	700 - 1,650 kg/h	15.0 kW	15.0 kW
TASK 7-2	2 x 437 cm ²	1,000 - 3,000 kg/h	22.0 kW	18.5 kW
TASK 8-2	2 x 538 cm ²	2,000 - 5,000 kg/h	32.8 kW	22.0 kW