

Screen Changer TSD

for discontinuous filtration

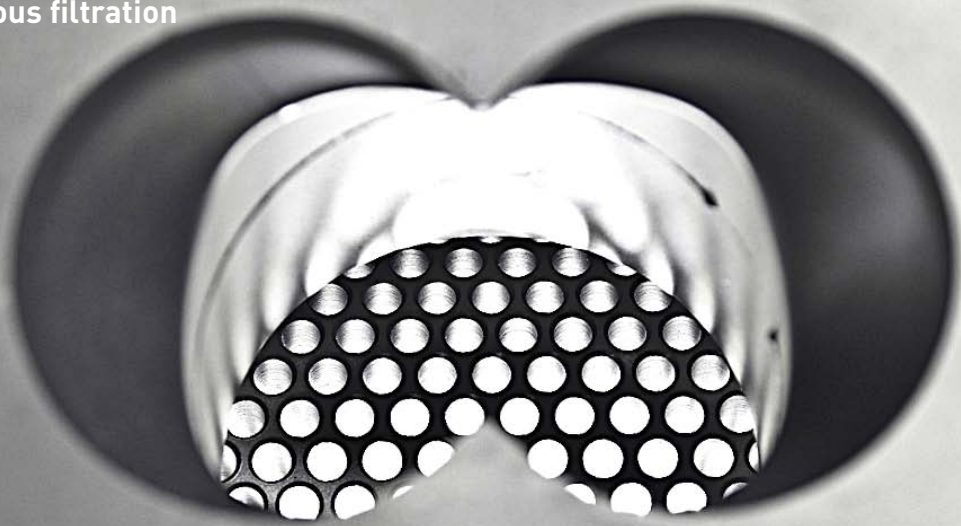

- One screen cavity
- Easy to operate
- Rectangular breaker plate

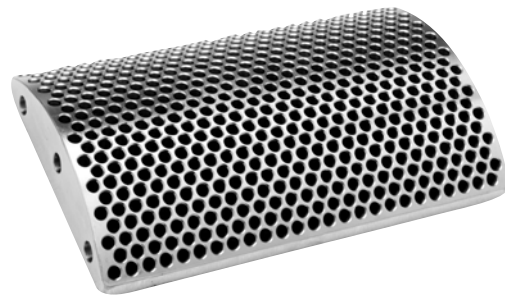

Discontinuous screen changers from Trendelkamp are built to meet the highest quality standards in polymer melt filtration. TSD screen changers are based on the proven dual bolt design and are highly reliable.

Unique to all Trendelkamp screen changers are the curved and rectangular breaker plates. Utilizing this rectangular design offers the largest screen area per bolt size, enabling smaller overall machine size to operate greater throughputs. Furthermore, our thin, curved breaker plate design optimizes strength while maintaining more uniform bore length throughout the plate. The Trendelkamp TSD screen changer is suitable for a variety of extrusion applications that allow for short interruptions in production. For example, polymers with low levels of contamination, or melt pump protection.

Benefits:

- Reliable operation
- Fewer screen changes and lower screen cost
- Reduced shear stress on product
- Reduced pressure drop across screen changer
- Safe, easy operations and reduced maintenance

Options:

- Oil, steam or electrical heating
- High-temperature design, up to 450°C
- Special coating for abrasive/corrosive applications
- Stainless steel design
- Hazardous area design

Screen Changer TSD



Functional Principle:

A rheological optimized flow channel leads the incoming polymer melt stream into a screen cavity. Inside the screen cavity a breaker plate is equipped with a filtration screen pack suitable for the required filtration fineness.

When a screen change is required, the bolt is moved hydraulically out of the housing so the screen pack can be changed. During this process the bolt blocks the melt flow until the required screen change has been completed and the bolt moves back into production mode.

Control Options:

- Manual hand control system
- PLC control system
- Control system preparation for external PLC
- Heating control system
- Pressure and temperature monitoring

Applications:

- Compounding
- Masterbatch
- Polymerization
- Fiber
- Sheet/Film
- Profile/Pipe
- EVA, Hot Melt Adhesives

Design Features:

- Hydraulically operated
- Operating limits: 400 bar/400°C
- Differential pressure: up to 100 bar
- Energy efficient due to insulated housing

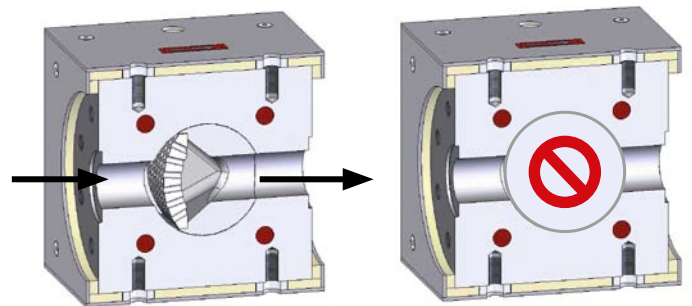

Production

Screen Change

Screen Changer TSD >>> Data based on: Polyolefin's, Filter fineness 200 µm				
Model	Filter Area	Extruder Throughput	Heating Power	Hydraulic Power
TSD 2-2	1 x 20 cm ²	- 70 kg/h	2.0 kW	1.1 kW
TSD 3-2	1 x 48 cm ²	70 - 170 kg/h	3.0 kW	3.0 kW
TSD 4-2	1 x 87 cm ²	160 - 350 kg/h	4.0 kW	3.0 kW
TSD 5-2	1 x 161 cm ²	300 - 650 kg/h	5.0 kW	3.0 kW
TSD 6-2	1 x 270 cm ²	450 - 1,000 kg/h	6.4 kW	5.5 kW
TSD 7-2	1 x 437 cm ²	800 - 2,100 kg/h	8.0 kW	5.5 kW
TSD 8-2	1 x 538 cm ²	1,000 - 2,700 kg/h	10.0 kW	5.5 kW
TSD 9-2	1 x 759 cm ²	1,400 - 3,600 kg/h	12.8 kW	7.5 kW
TSD 10-2	1 x 875 cm ²	1,750 - 4,600 kg/h	25.6 kW	7.5 kW